

BRAKE SYSTEMS

I would like to thank Kent Singer for providing the drawings used below detailing the various parts of the typical brake system. In addition to the drawings Kent has provided a listing of various manufacturers who produce different parts of these systems and some reference works that can be used to obtain more information on the history and functioning of these systems.

On the facing page are copies taken from the plans for the Hoquat Hobbies Michigan Central refrigerator kit (also drawn by Kent) showing a KC system from a side view and an underneath view.

Hopefully you will find this material interesting and informative. If you have any questions on underbody detailing, write in and we'll try to answer them.

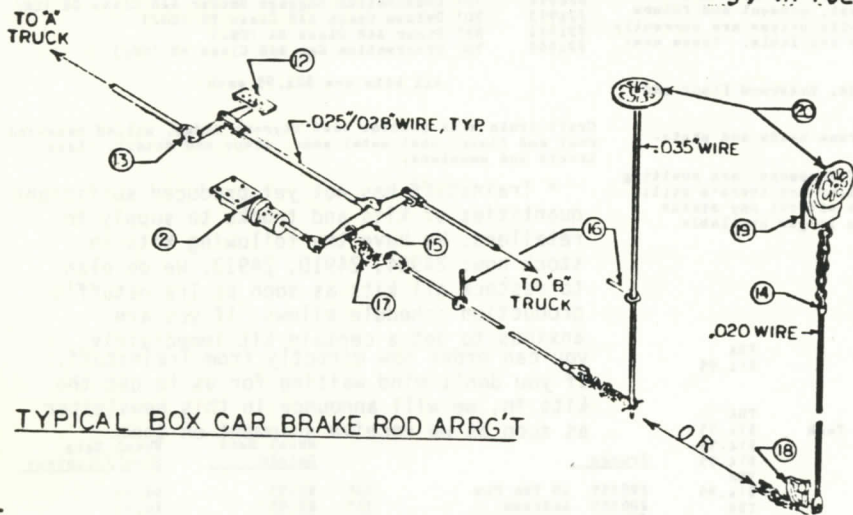

TYPICAL BOX CAR BRAKE ROD ARR'GT

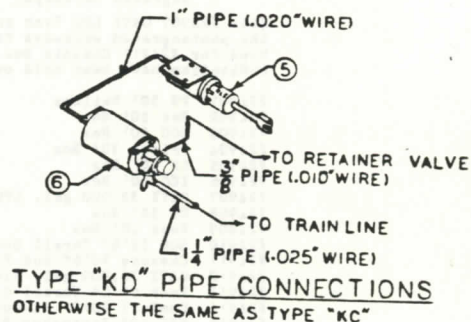

TYPE "KD" PIPE CONNECTIONS
OTHERWISE THE SAME AS TYPE "KC"

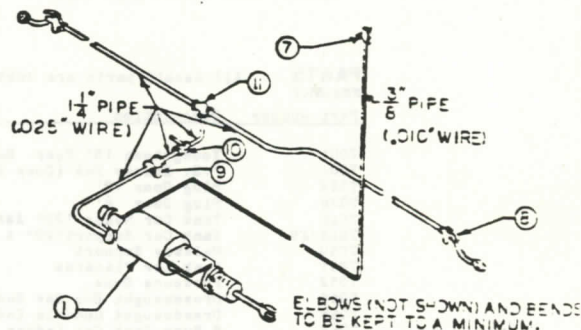

TYPE "KC" FREIGHT CAR BRAKE PIPING
VIEWED FROM TOP, THRU FLOOR OF CAR

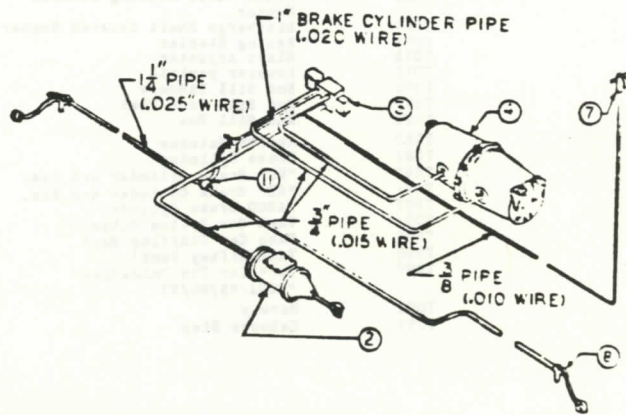

TYPE "AB" FREIGHT CAR BRAKE PIPING
VIEWED FROM TOP, THRU FLOOR OF CAR

BRAKE SYSTEM PARTS

ITEM	DESCRIPTION	SCALE SOURCE
1	Type "KC" Brake Cylinder/Valve/Reservoir	Buff-n-Puff #2517 Train Stuff #T090 Tomaleo #T-3001 Bio Grande Models #3315 } Sng V & T Shops #S-102
2	Type "AB" Brake Cylinder	Liberty Models #SAB Buff-n-Puff #2518
3	Triple Valve	Mckean Modern Brake Set (Walther's #457-10) Cylinder only, WABCO-Train Stuff #T-092
4	Air Reservoir	FIABE-Train Stuff #T-084
5	Type "KD" Brake Cylinder	Train Stuff #T-091
6	Type "KD" Brake Valve/Reservoir	
7	Retainer Valve	Tomaleo #T-3005
8	Angle Cook, Hose & Glad Band	Tomaleo #T-3013
9	Dirt Collector	
10	Cut-Out Cook	
11	Pipe Tee	Tomaleo #T-4005
12	Slack Adjuster Plate	Cyl & Drill, .010" Brass or Styrene
13	Clevis, Large	Tomaleo #T-4012
14	Clevis, Small	Tomaleo #T-4013
15	Lever	Cut out of .010" brass or styrene Also, part of Liberty Models #SAB
16	Eye Pin	Northeastern .018" x 3/4" long brass
17	Chain	Clover House #221
18	Bell Crank	May be made out of part in Liberty #SAB
19	Ajax Brake Housing	Buff-n-Puff #2516 Part of Liberty Models #SAB
20	Brake Wheel	Buff-n-Puff #2516 Part of Liberty Models #SAB Part of Mckean set (Walther's #457-10)

References: Car Builders Cyclopedia, L. W. Simmons Boardman, republished by Kalmbach Publishing Co., 1973, Pp 981 & 1079

NRRA DATA BOOK NO. 1, Section D9n, National Model Railroaders Assoc.

The Westinghouse Air Brake Story, D.C. Blaine, Kalmbach, 1975

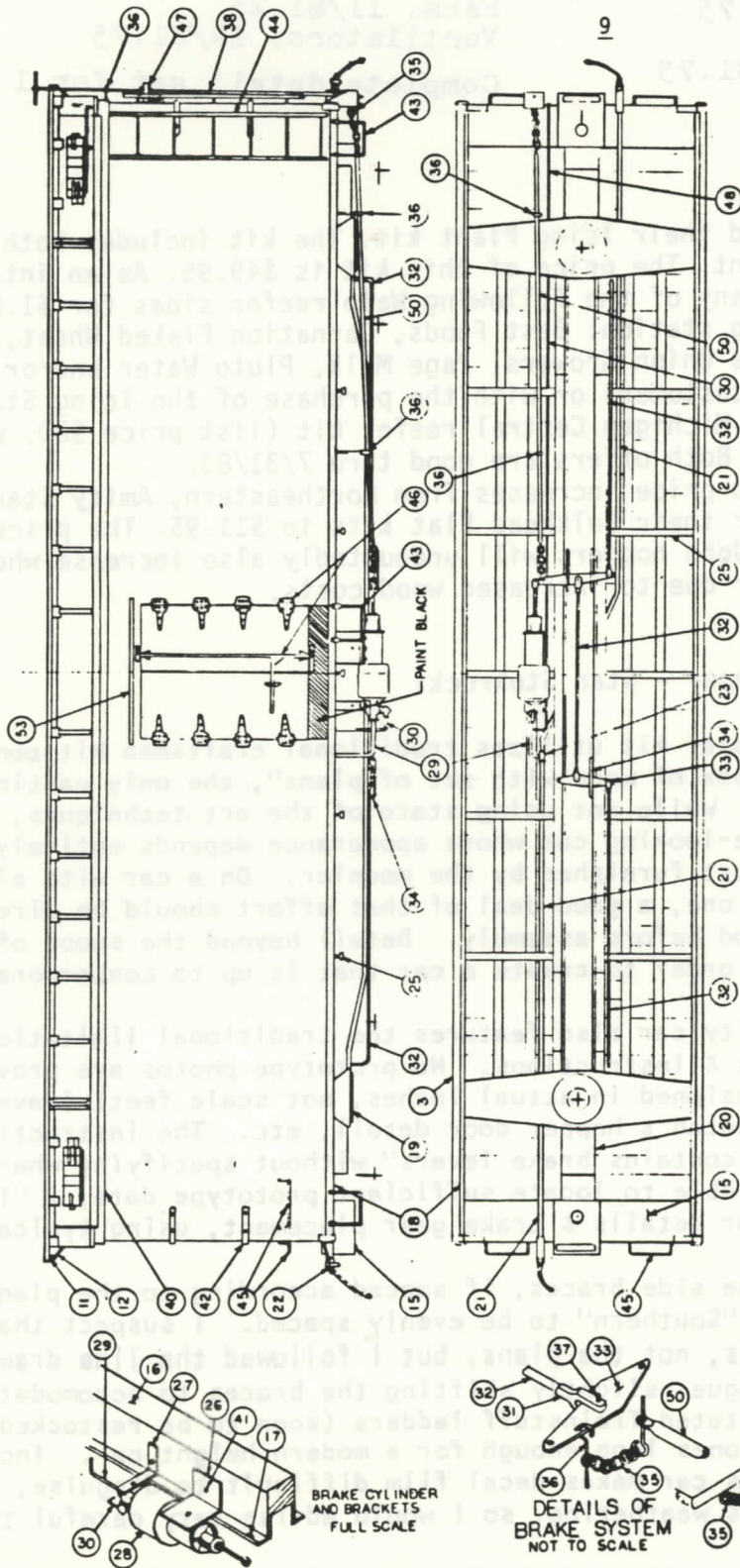

ITEM	QTY	DESCRIPTION
53	2	DRIPSTICK, 1/32" x .012" x 1"
52	2	UNCOUPLING (CUT) LEVER, WIRE, .015"
51	1	BRAKE WHEEL
50	1	HAND BRAKE ROD, WIRE, .025" x 3-1/4"
49	1	RETAINER VALVE
48	1	RETAINER VALVE LINE, UPPER WIRE, .015"
47	1	BRAKE PLATFORM
46	1	SET: DOOR HARDWARE
45	8	GRAB IRON
44	4	LADDER
43	6	STEP
42	8	CORNER BRACE, FLAT WIRE, 1/64" x 1/16" x 1/2"
41	2	PIN, 1/2"
40	2	SIDE FASCIA, 1/32" x 3/32" x 7-13/16"
39	4	END FASCIA, 1/32" x 3/32" x 15/16"
38	1	BRAKE STAFF, WIRE, .032" x 2-1/4"
37	5	BRAKE CLEVIS PIN, WIRE, .015" x 1/8"
36	11	EYE PIN
35	2	CHAIN, 1/2"
34	3	BRAKE HANGER, WIRE, .015" x 3/4"
33	2	BRAKE LEVER, FLAT WIRE, 1/64" x 1/16" x 5/8"
32	1	BRAKE ROD, WIRE, .025" x 10"; CUT TO SUIT
31	4	LARGE CLEVIS
30	1	RETAINER VALVE LINE, LOWER, WIRE, .015" x 5'
29	1	CYLINDER LINE, WIRE, .025"
28	1	BRAKE CYLINDER, K TYPE
27	1	SMALL BRAKE CYLINDER BRACKET, FLAT WIRE, 1/64" x 1/16" x 7/16"
26	1	LARGE BRAKE CYL. BKT, SH. BRASS, 3/8" x 7/16" x 1.05
25	10	"I" BEAM, 3/32" x 21/32"
24	4	STRINGER, 1/16" x 1/16" x 5-5/8"
23	1	PIPE "TEE"
22	2	GLADHAND, HOSE / ANGLE COCK
21	2	TRAINLINE, WIRE, .025" x 4-1/8"
20	2	CENTERSILL EXTENSION, 3/16" x 1/4" x 13/16"
19	2	BOLSTER
18	2	SIDE SILL, 1/32" x 3/32" x 7-7/8"
17	2	CENTERSILL FLANGE, 1/32" x 1/16" x 5-7/8"
16	1	DEEP FISHBELLY CENTERSILL, 5-5/8"
15	1	END SILL, PAIR
14	4	ROOF GRAB IRON, WIRE, .015"
13	4	ICE HATCH
12	4	ROOFWALK END SUPPORT, WIRE, .025"
11	2	ROOFWALK END, 1 3/2" x .012"
10	3	ROOFWALK, 1/32" x 3/32" x 7-25/32"
9	24	ROOF RIB, 1/32" x .012" x 25/32"
8	4	ROOF RIB, "TEE", 1/16" x 25/32"
7	20	ROOFWALK SUPPORT, 1/16" x 1/16" x 5/16"
6	4	END EAVE, 1/8" x 1/32" x 15/16"
5	2	END BLOCK, 1-5/16"
4	2	END, MC/MDDL
3	2	SIDE, MC/MDDL
2	1	FREIGHT FLOOR x 7-5/8" w/ NOTCHES
1	1	OVERHANGING ROOF x 7-5/8"

