

ASSEMBLY INSTRUCTIONS

NIMCO 6-WHEEL PULLMAN TRUCKS, CATALOG #P-11

6-WHEEL COMMONWEALTH TRUCKS, CATALOG #P-12

6-WHEEL PENNSYLVANIA TRUCKS, CATALOG #P-15

- * Clean all flash from edges of castings with a small file or knife.
- * Insert Brass Bearing (grommet) (1) in truck side frame holes (2).
- * Place side frames and bearings over wheels (3). Make sure all insulated wheels are on same side of truck. NOTE: Some wheel sets will be supplied with both wheels insulated from axle. If your wheels are of this type, it will make no difference how they are installed.
- * Fit bolster (4) in place and fasten same with self-tapping screws(5).
- * Place truck assembly on track or flat surface to check that all wheels are bearing equally. Side frames may be bent up or down slightly to make this adjustment.
- * It will be necessary to file more on the sides of side frame mounting lugs (6) to allow sufficient clearance for wheels on P-12 trucks.

NIXON MODEL COMPANY

BOX 514

SOUTHAMPTON, PENNA.

NOTE: These instructions
also apply to NIMCO
#P-15 6-wheel
Pennsylvania type
passenger trucks.

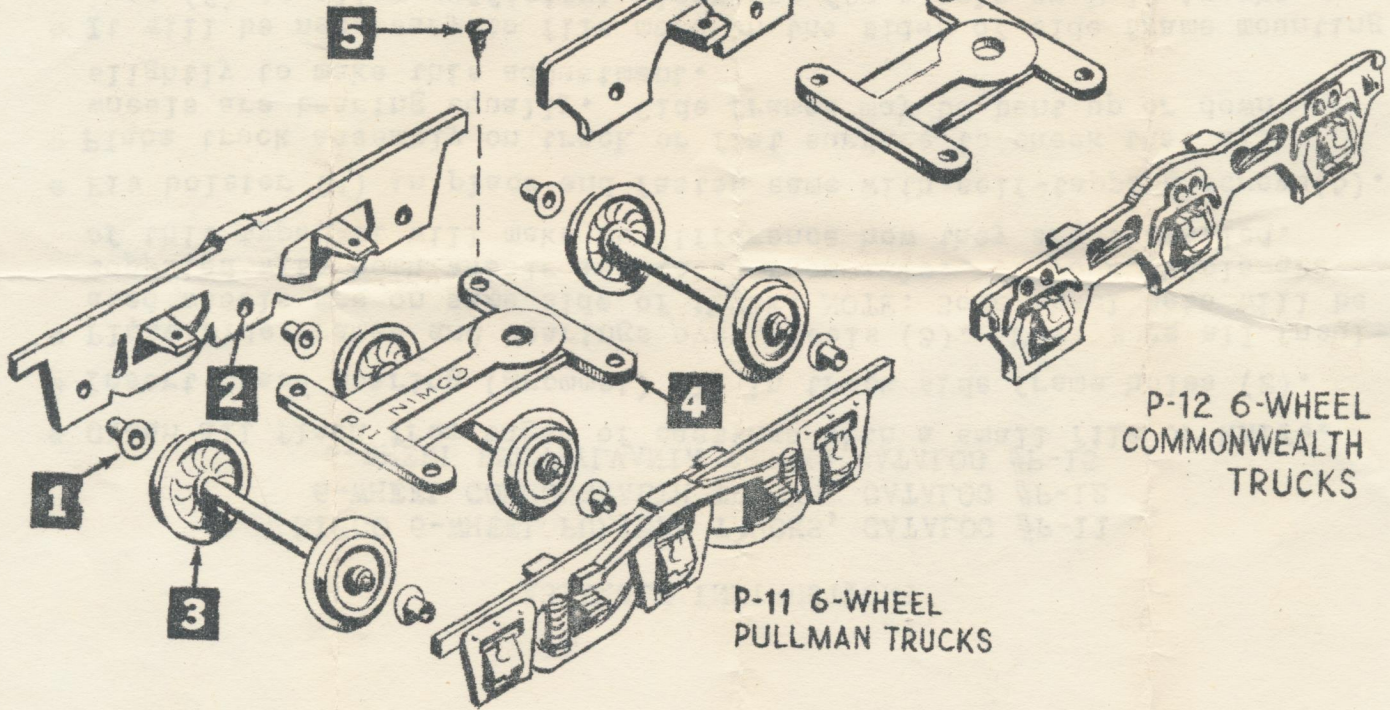

P-12 6-WHEEL
COMMONWEALTH
TRUCKS

P-11 6-WHEEL
PULLMAN TRUCKS